

IAR

Intelligent Anomaly Recording

Overview

- Problem: Unknown and potentially hazardous error patterns in sensor data endanger autonomous vehicles
- Challenge: The test space is infinite and unknown error patterns should be detected
- Proposed solution: AI-based triggers to detect sensor anomalies in automotive sensor data

Motivation - Certification of Autonomous Vehicles

- ISO 21448 - safety of the intended functionality (SOTIF) [1] requires operation phase activities
- Main cause of malfunction is frequently the sensor system
- Triggers for potentially hazardous behavior enable operation phase activities

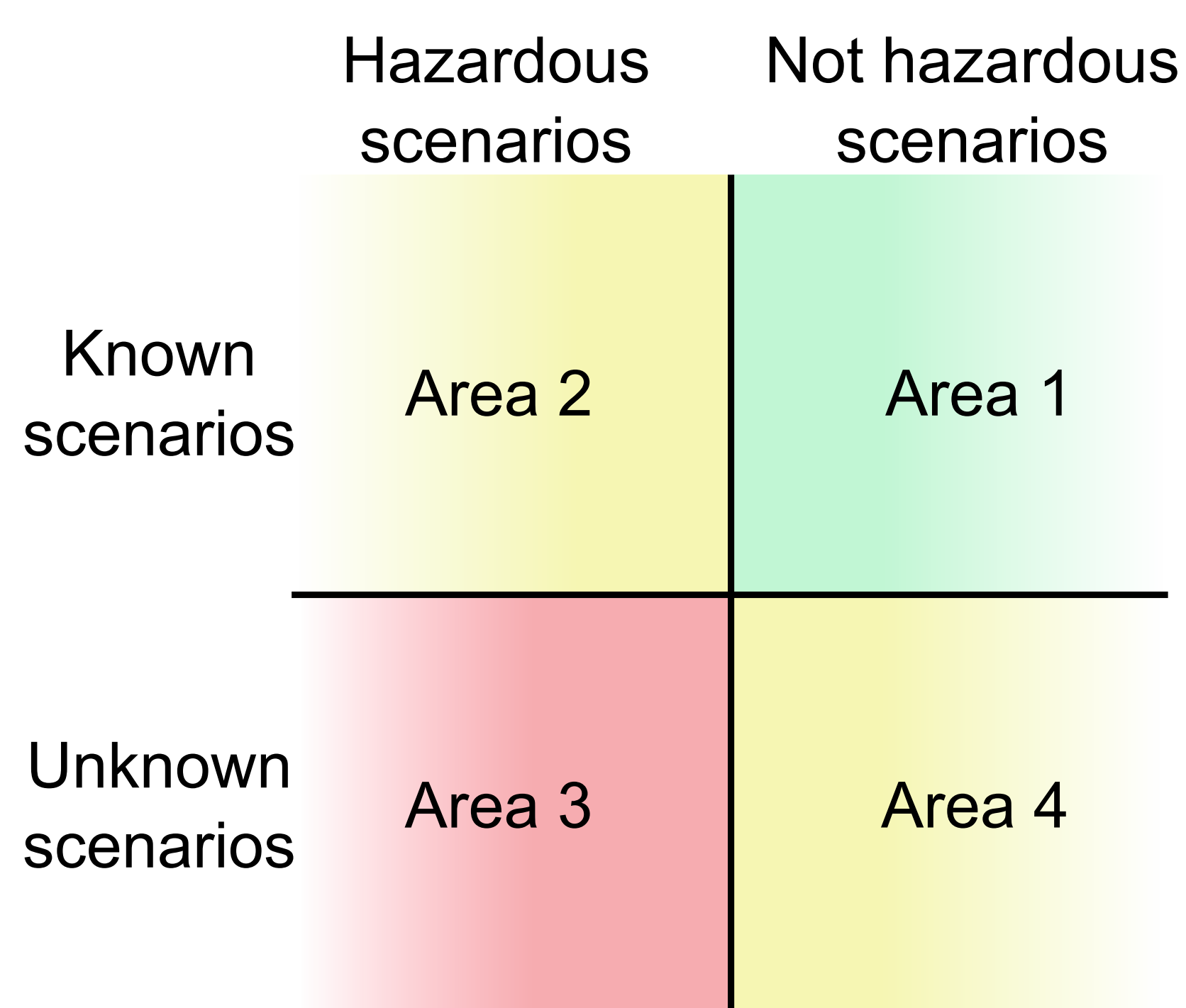

Figure 1: Scenario categories from SOTIF [1]

→ Intelligent triggers to detect sensor anomalies in the operation phase

Machine Learning Methods for Intelligent Triggers

- Self Supervised Learning (SSL)

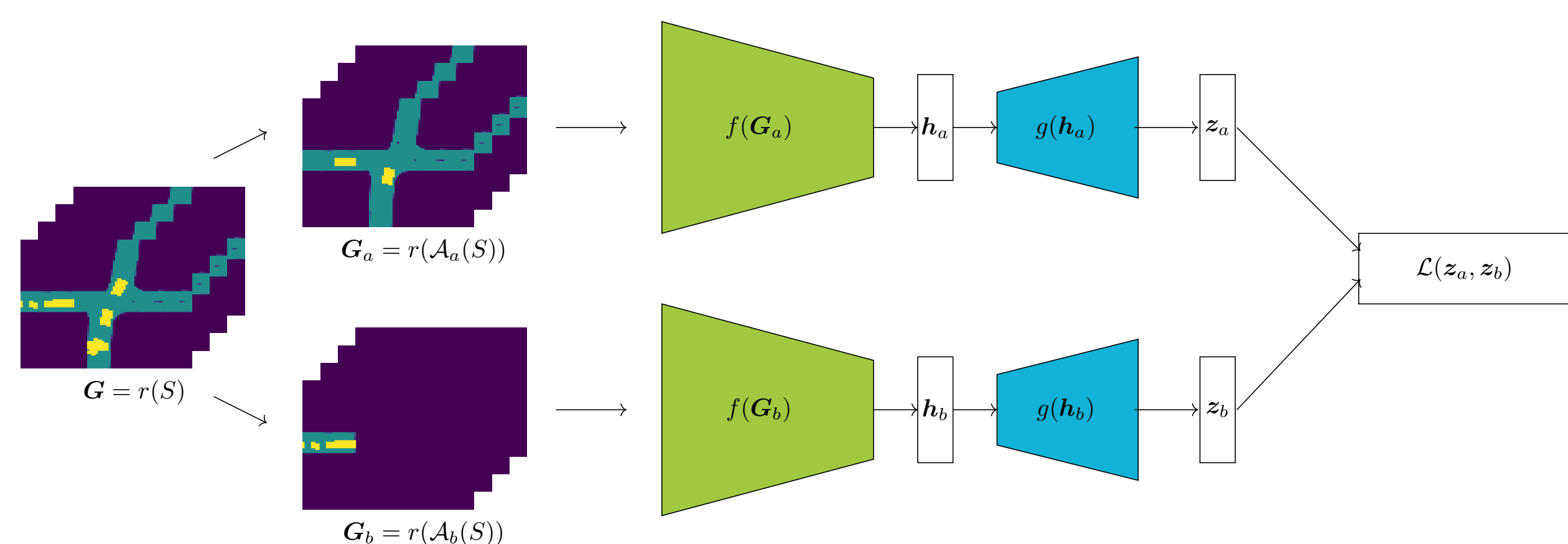

Figure 2: SSL model architecture [2]

- Transformer

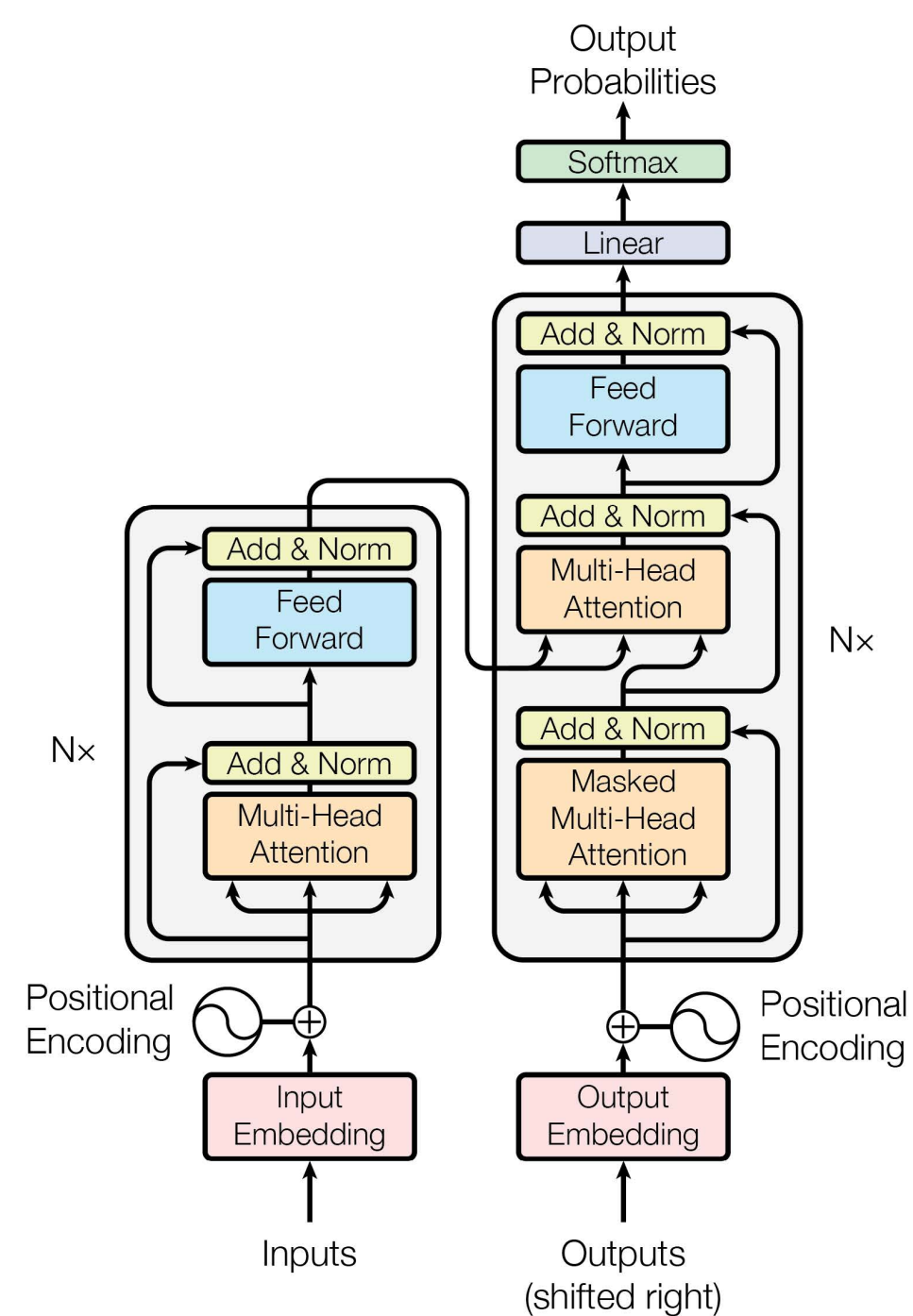

Figure 3: Model architecture of attention mechanism [3]

- Autoencoder

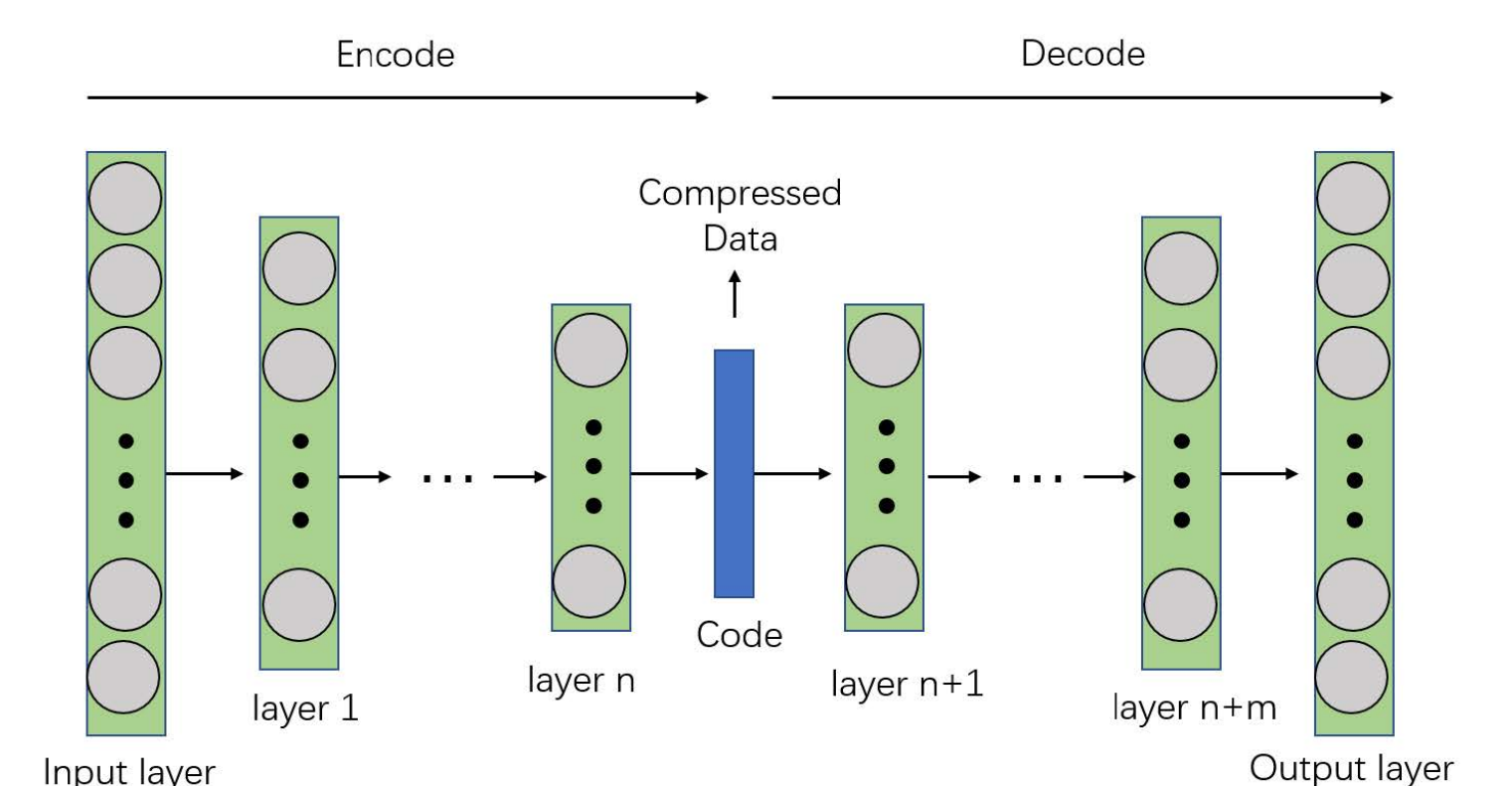
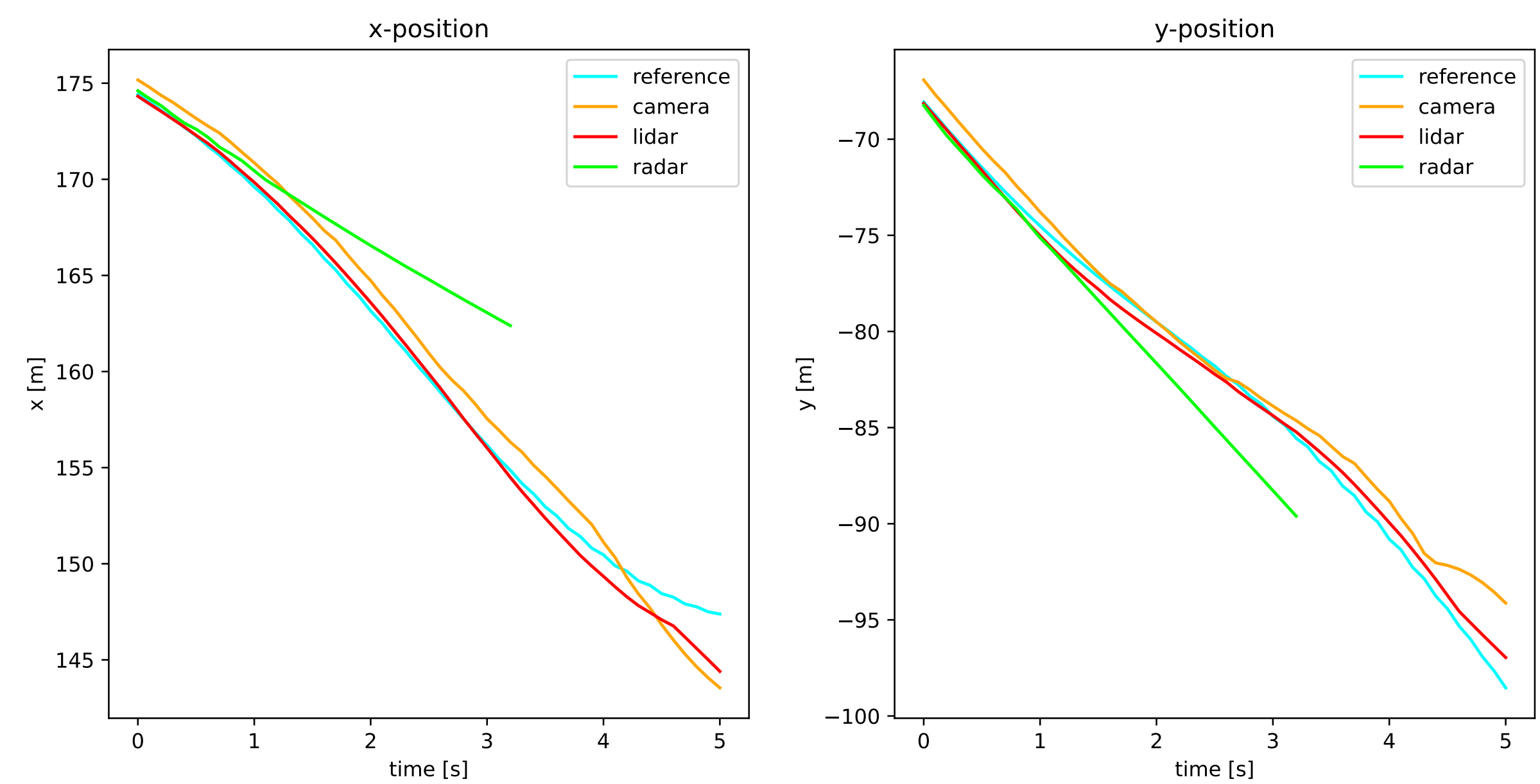

Figure 4: Model architecture of autoencoder [4]

Dataset

Dataset requirements:

- Real world autonomous sensor data
- Dataset contains various independent sensor channels (e.g. camera, lidar, and radar)
- Sensors cover the same region of interest in the same scenario



Concepts

- Embedding of object attributes in the latent space
- Clustering of the latent embeddings.

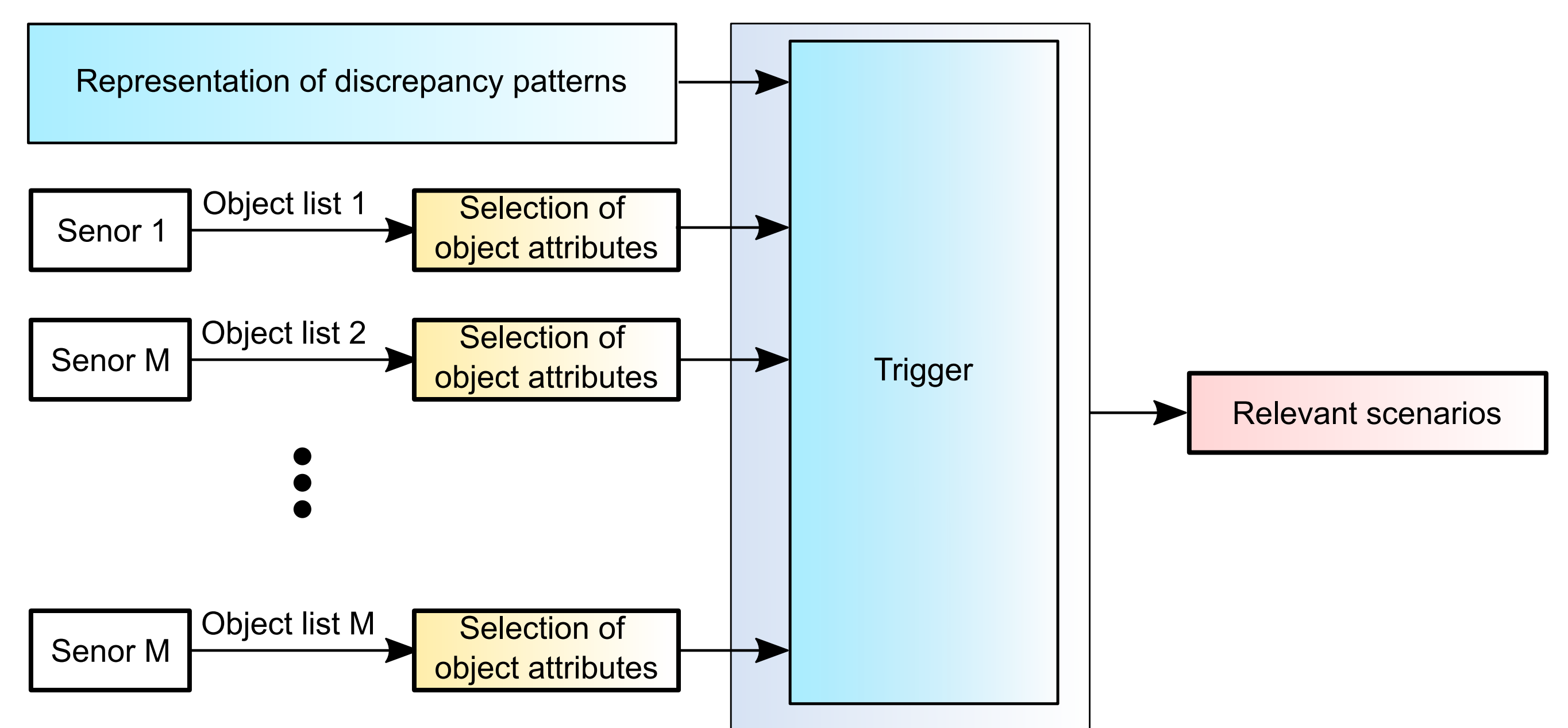
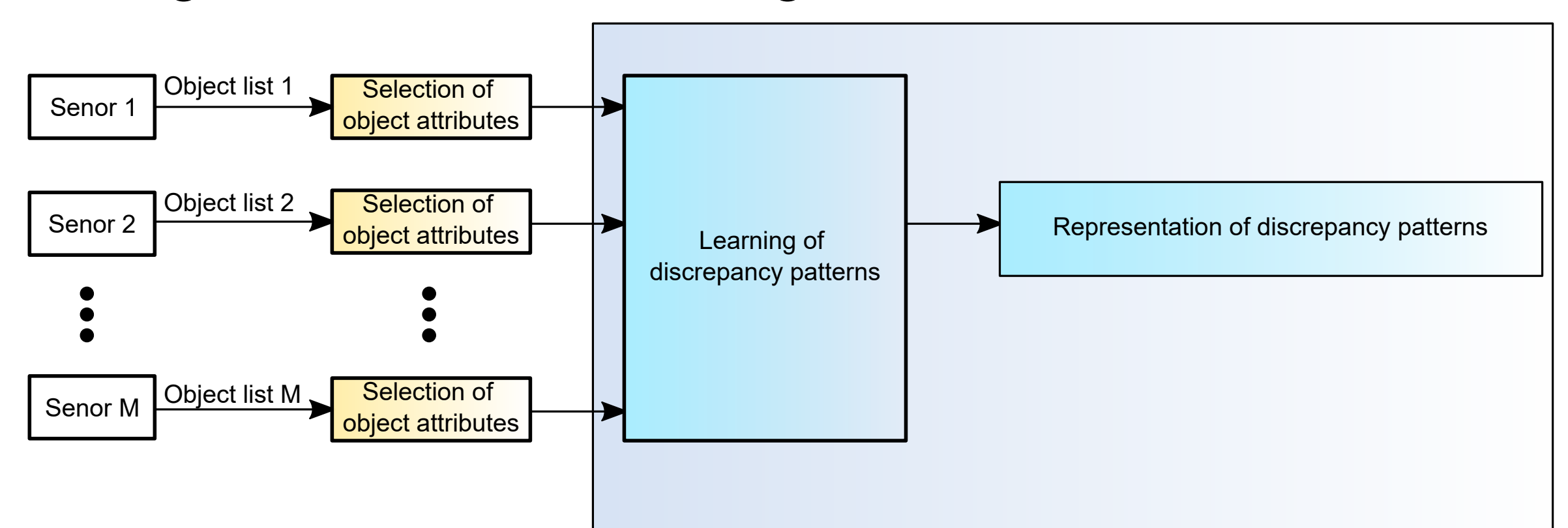

Outlook

- Development of intelligent triggers to find sensor anomalies and enable operation phase activities for autonomous vehicles
- Detection of unknown and hazardous scenarios (SOTIF area 3)

References

- "Iso 21448 - road vehicles — safety of the intended functionality (sotif)," standard, International Organization for Standardization, Geneva, CH, 2021.
- L. Balasubramanian, J. Wurst, R. Egolf, M. Botsch, W. Utschick, and D. Ke, "Exagt: Expert-guided augmentation for representation learning of traffic scenarios," in *2022 IEEE 25th International Conference on Intelligent Transportation Systems (ITSC)*, 2022.
- A. Vaswani, N. Shazeer, N. Parmar, J. Uszkoreit, L. Jones, A. N. Gomez, L. Kaiser, and I. Polosukhin, "Attention is all you need," in *Advances in Neural Information Processing Systems* (I. Guyon, U. V. Luxburg, S. Bengio, H. Wallach, R. Fergus, S. Vishwanathan, and R. Garnett, eds.), vol. 30, Curran Associates, Inc., 2017.
- T. He, L. Zhang, F. Kong, and A. Salekin, "Exploring inherent sensor redundancy for automotive anomaly detection," in *2020 57th ACM/IEEE Design Automation Conference (DAC)*, pp. 1–6, 2020.